

MERKENPOSTLIST Merk: LV-1
conserving: Painted

lengte (mm): 10584

Pos	Profiel	Materiaal	Aantal	Lengte (mm)	Gewicht (kg)
LV-1	HEA140	S235JR	1	10584	254,2
PR-1004	PLP82	S235JR	1	271	0,9
PR-1012	STRIP80	S235JR	1	80	0,4
PR-1014	PLP94,7	S235JR	1	132	0,6
PR-1015	PLP84,4	S235JR	1	119	0,5
PR-1020	PLP77	S235JR	2	132	1,2
PR-1021	PLP87,3	S235JR	6	114	2,8
PR-1036	STRIP100	S235JR	1	286	3,6
PR-1037	STRIP100	S235JR	1	116	0,9
PR-1069	STRIP100	S235JR	1	300	4,0
PR-1204	STRIP100	S235JR	1	151	1,6
PR-1216	STRIP100	S235JR	2	102	1,9
PR-1281	STRIP100	S235JR	2	140	2,6
PR-1301	STRIP100	S235JR	2	121	3,0
PR-1380	STRIP100	S235JR	2	220	9,5
PR-1484	STRIP150	S235JR	1	245	5,2
PR-1488	STRIP150	S235JR	1	160	2,6
PR-1607	PL12025	S235JR	1	200	8,0
PR-1048	L707	S235JR	1	482	30,1
PR-1083	L707	S235JR	1	600	48,4
PR-1183	L707	S235JR	1	210	1,5
PR-1191	L707	S235JR	1	10145	74,8
PR-1198	L707	S235JR	1	370	2,7
PR-1222	L707	S235JR	1	169	1,2
PR-1300	HEA100	S235JR	1	6006	199,5
PR-1312	HEA100	S235JR	1	4008	122,5
PR-1336	HEA100	S235JR	1	230	7,0
PR-1337	HEA100	S235JR	1	422	7,0
PR-1338	HEA100	S235JR	1	1030	17,2
PR-1339	HEA100	S235JR	1	1409	23,5
PR-1340	HEA100	S235JR	1	622	10,4
PR-1381	K703	S235JR	1	1772	11,0
PR-1382	K703	S235JR	1	2151	13,3
PR-1383	K703	S235JR	1	1891	12,3
PR-1501	K6034	S235JR	6	210	8,5
PR-1531	L200100/10	S235JR	7	140	22,3

Totaal per croon: 913,8

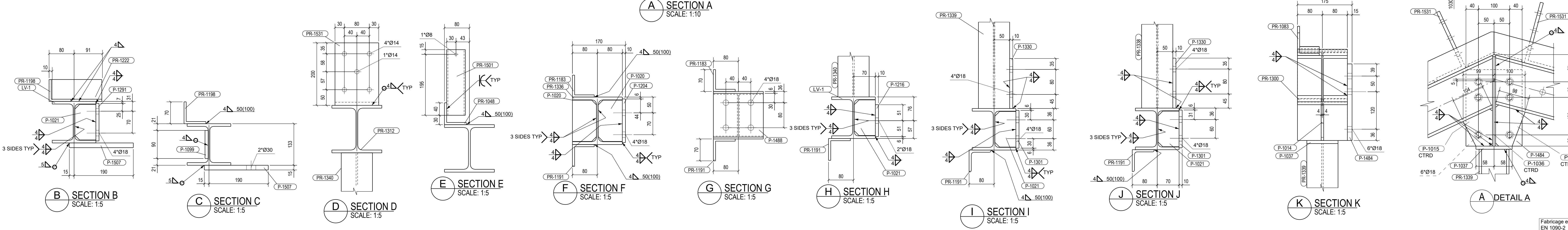

Werk:	Getekend: tekenaar	MATERIAALKWAL: S235JR TENZU ANDERS VERMELD	LASSEN: 4, TENZU ANDERS VERMELD
Onderwerp:	Datum: 20.04.2020	BOUTENKWALITEIT 8.8, TENZU ANDERS VERMELD	PROJECTIE: PROJECTIE
Opm: Opdrachtgever:	Schaal: 1:5 1:10		
			Project: Tekening: A [LV-1] Revisie: 0 Formaat: AO Status: 0

0 FOR FABRICATION
Rev. no. Revisie omschrijving 26.04.2020
Revisie datum

Fabricage en montage volgens EN 1090-2
Uitvoeringsklasse: 0
Functionele tolerantie klasse: 0